

Project:	Type:
Date:	Comments:

BLUZAP - Germicidal UVC / LED combination Architectural Linear Fixture

- Wattage** - LED - 25W/40W/50W
- LED Light Source** - Samsung LED Chips - 2700-6000K, 82CRI (90 Optional) Tunable White Optional
- UV-C Light Source** - 3.3' Quartz, 120W hot cathode UV-C tube
- Irradiance** - 253.7nm wavelength, UVC output of 400uw/cm²
- Voltage** - 110-277V
- Construction** - 2 6/8" x 3 1/8" High Grade Aluminum Extrusion; reflective louvre grill
- Installation** - Pendant, Surface Mount & Recessed
- Control** - Bluetooth Mesh, controllable by iOS & Android app, integrated with motion sensor
- Compliance** - cETLus for UL1598 CSA C22.2#250.0:2008; FCC Compliant with Part 15 Class A; EPA
- Patent pending**

Architectural linear fixture with combination of LED light source for general illumination and UV-C for disinfection. It emits UV-C light proven to kill microorganisms, including bacteria, protozoans and fungi, also deactivates viruses, including SARS-CoV-1.

This UV-C light, to be used overnight or at times when no one is on premises, effectively disinfects the entire area treated, including surfaces and air, leaving no chemicals or residue, unlike traditional disinfection techniques.

The fixtures are linkable for continuous linear runs, direct or direct/indirect LED general illumination and pendant, surface mount or recessed installation.

Controlled by integrated Bluetooth Mesh technology, controllable by iOS and Android applications with full functionality to control the LED

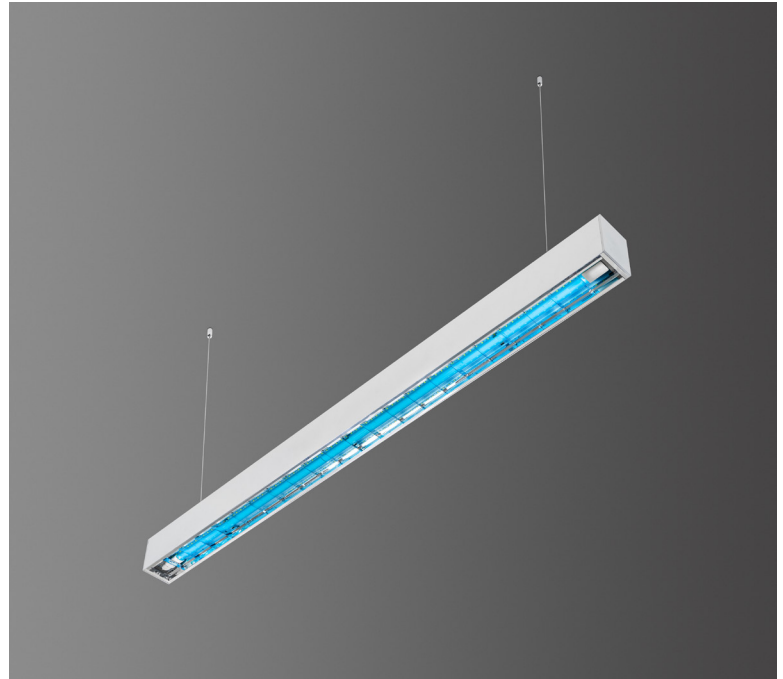

COMMERCIAL | RETAIL | EDUCATION | INDUSTRIAL | MEDICAL



Model #	Wattage	LED lumen output	UV-C Wattage	Fixture Dimensions
BLUZAP-L1-D-4-25-30	25W	2750lm	120W	48" x 2 6/8" x 3 1/8"
BLUZAP-L1-D-4-40-30	40W	4400lm	120W	48" x 2 6/8" x 3 1/8"
BLUZAP-L1-D-4-50-30	50W	5500lm	120W	48" x 2 6/8" x 3 1/8"

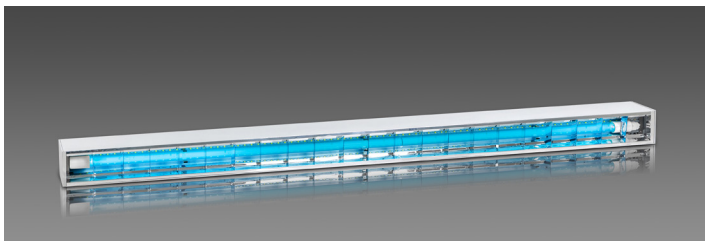

Project:	Type:
Date:	Comments:

ORDERING GUIDE

1-FIXTURE ID	2-DISTRIBUTION	3-LENGTH	4-WATTAGE (LED)	5-COLOR TEMPERATURE
L1 - L1 Series	D - Direct DI - Direct/Indirect	4 - 4ft	25 - 25W 40 - 40W 50 - 50W	27 - 2700K 30 - 3000K 35 - 3500K 40 - 4000K 50 - 5000K D - Dynamic/Tunable White
6-VOLTAGE	7-FINISH	8-MOUNTING	9-OPTIONS	
U - Universal 110-277V	S - Silver W - White B - Black C - Custom (RAL#)	P - Pendant S - Surface Mounted R - Recessed TG - Recessed in T Grid Ceiling	M - Motion Sensor (standard) S - Smart Wireless Control (standard)	

TECHNICAL DRAWING

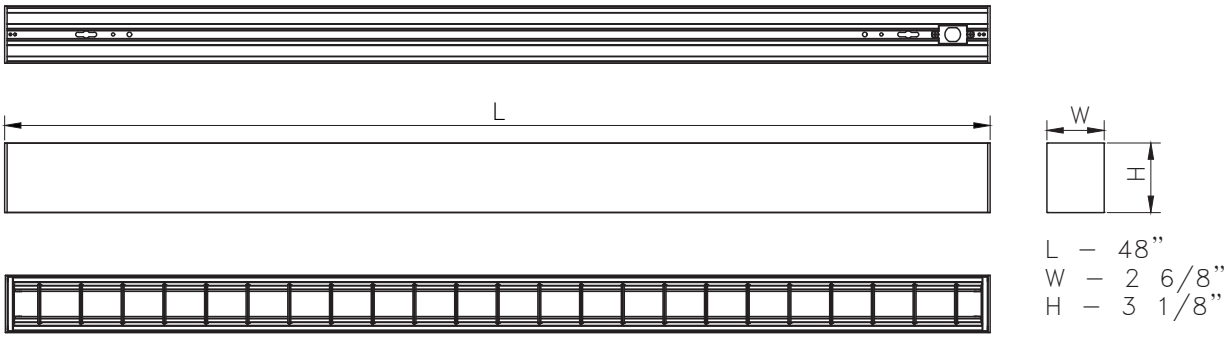

UNDERSTANDING UV

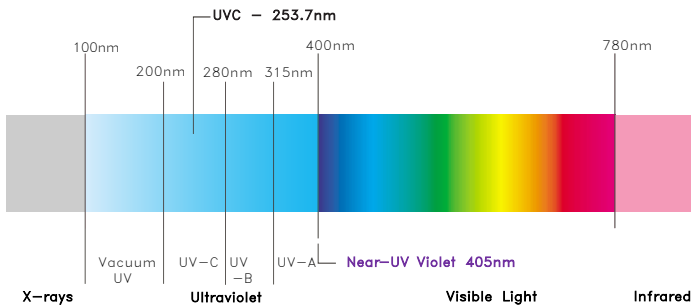

- UV-C - germicidal ultraviolet light - is a proven technology to effectively disinfect air and surface
- 253.7nm refers to the most effective wavelength frequency of the ultraviolet light
- UV-C can cause health hazard to the skin and eyes if improperly installed and used

Please refer to our website for more detailed information and links to independent research here "link"

Project:	Type:
Date:	Comments:

CONTROLS

BLUZAP UV-C / LED combination devices are equipped with integrated components and connected to Bluetooth Mesh network and fully controlled by iOS or Android application provided by BubblyNet® and locally supported. Each fixture is equipped with motion sensor that will shut the UV-C lamp off when anyone enters the area. The fixture can be programmed for different modes and functions of standard LED and UV-C illumination. Timers can be set, for example for UV-C lamp can be programmed to come on from 12:00 – 4:30am, LED illumination can be programmed for night light function and more.

WIRING DIAGRAM

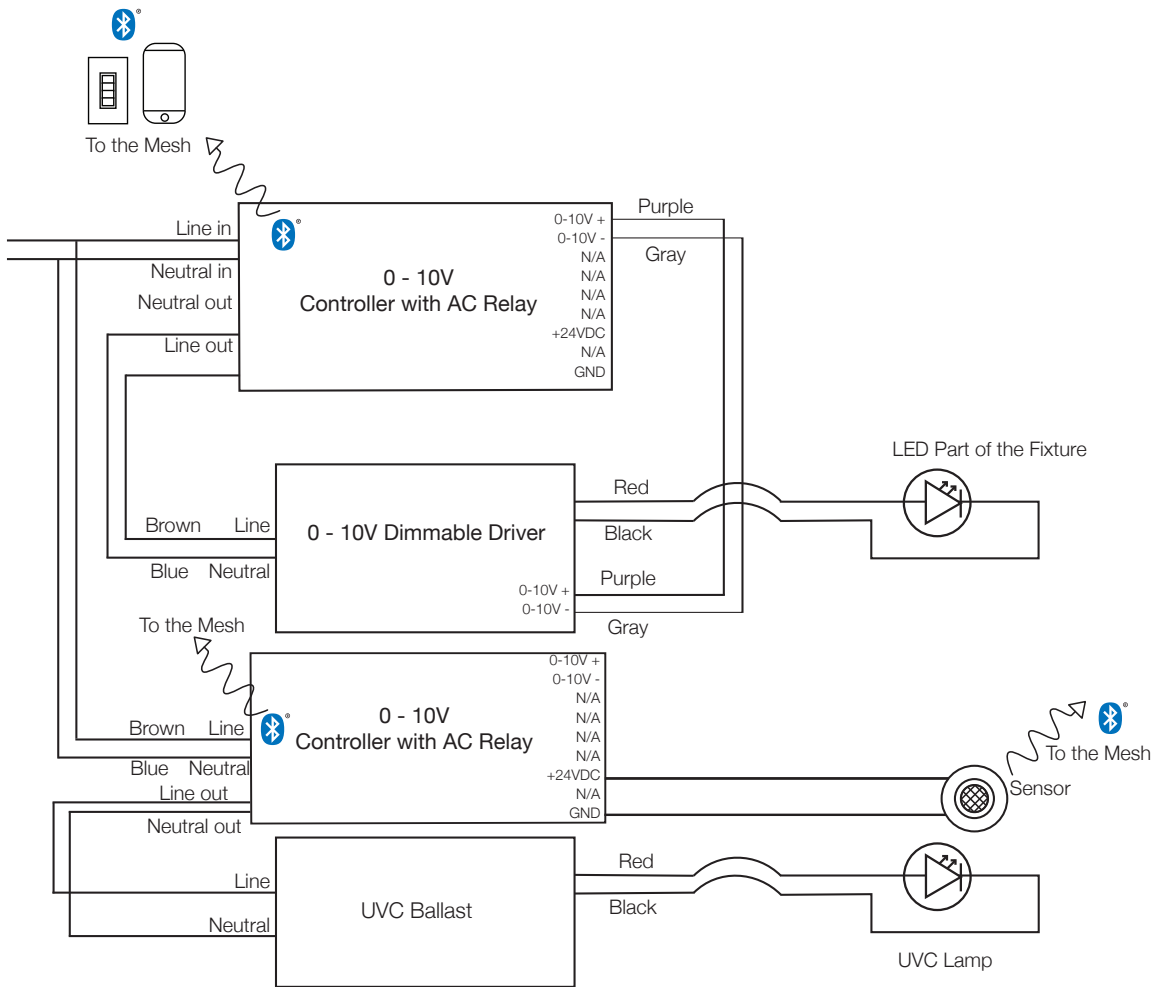

As we continue to innovate and improve our products, we reserve the right to edit, modify, and change our technical documentation.

Project:	Type:
Date:	Comments:

CONTROLS - CONTINUED

UNDERSTANDING BLUETOOTH MESH

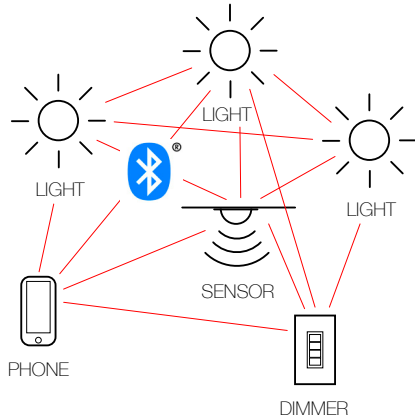

A SYSTEM WITH NO SINGLE POINT OF FAILURE
A BubbyNet installation does not have a single device from which all others depend for proper functioning. A BubbyNet installation is based on distributed intelligence rather than a system with centralized intelligence into one single device, which may fail.

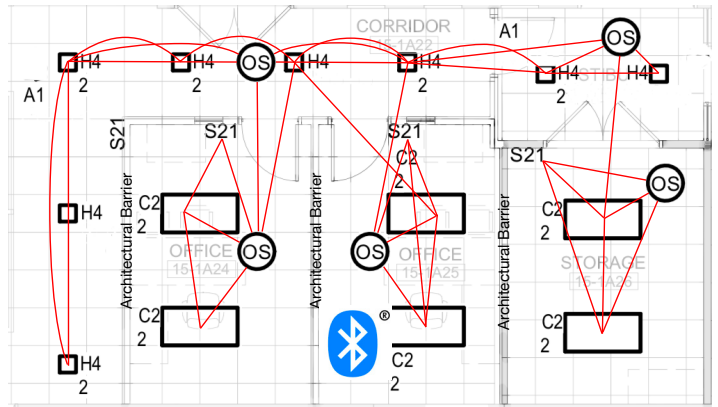

A SOLUTION TO RF BARRIERS
A Hub has a limited Radio Frequency coverage that reduces in the presence of architectural barriers, such as concrete walls and metal structures. In this case, multiple hubs need to be wired together. With a MESH architecture, the control signal is broadcasted and hops from device to device, "going around" architectural barriers. It is also called a "Self-Healing Network." If one device fails, the signal automatically re-routes bypassing the failed element.

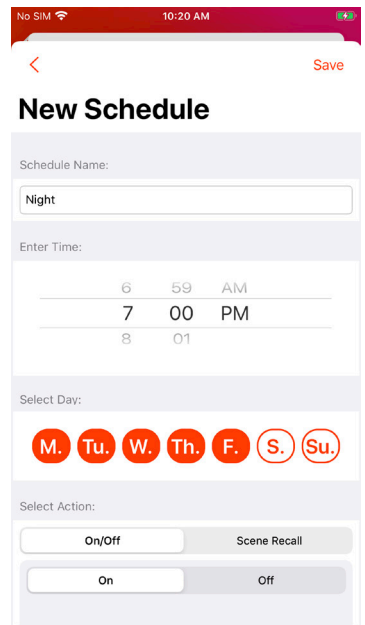
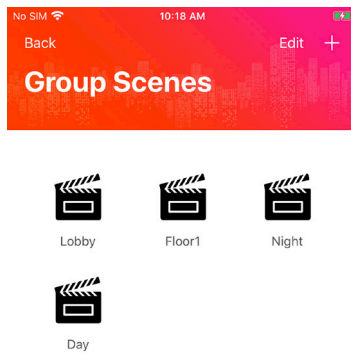
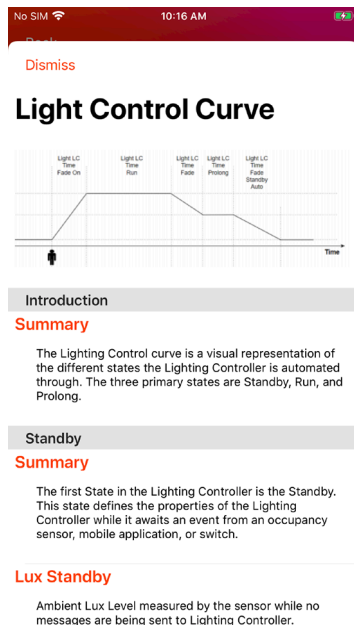
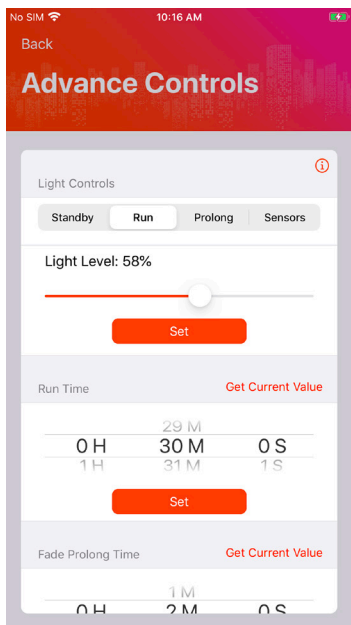

As we continue to innovate and improve our products, we reserve the right to edit, modify, and change our technical documentation.